



Installation Operation Maintenance

CGCL
Air Cooled Water Chiller With
Centrifugal Fans
Sizes 200 - 250 - 300 - 350 - 400 - 450 -
500 - 600



CGCL-SVX01B-E4



General information

Foreword

These instructions are given as a guide to good practice in the installation, start-up, operation, and maintenance by the user, of Trane CGCL chillers. They do not contain full service procedures necessary for the continued successful operation of this equipment. The services of a qualified technician should be employed through the medium of a maintenance contract with a reputable service company. Read this manual thoroughly before unit start-up.

Units are assembled, pressure tested, dehydrated, charged and run tested before shipment.

Warnings and cautions

Warnings and Cautions appear at appropriate sections throughout this manual. Your personal safety and the proper operation of this machine require that you follow them carefully. The constructor assumes no liability for installations or servicing performed by unqualified personnel.

WARNING! : Indicates a potentially hazardous situation which, if not avoided, could result in death or serious injury.

CAUTION! : Indicates a potentially hazardous situation which, if not avoided, may result in minor or moderate injury. It may also be used to alert against unsafe practices or for equipment or property-damage-only accidents.

Safety recommendations

To avoid death, injury, equipment or property damage, the following recommendations should be observed during maintenance and service visits:

1. The maximum allowable pressures for system leak testing on low and high pressure side are given in the chapter "Installation". Always provide a pressure regulator.
2. Disconnect the main power supply before any servicing on the unit.
3. Service work on the refrigeration system and the electrical system should be carried out only by qualified and experienced personnel.

General information

Reception

On arrival, inspect the unit before signing the delivery note.

Reception in France only:

In case of visible damage: The consignee (or the site representative) must specify any damage on the delivery note, legibly sign and date the delivery note, and the truck driver must countersign it. The consignee (or the site representative) must notify Trane Epinal Operations - Claims team and send a copy of the delivery note. The customer (or the site representative) should send a registered letter to the last carrier within 3 days of delivery.

Note: for deliveries in France, even concealed damage must be looked for at delivery and immediately treated as visible damage.

Reception in all countries except France:

In case of concealed damage: The consignee (or the site representative) must send a registered letter to the last carrier within 7 days of delivery, claiming for the described damage. A copy of this letter must be sent to Trane Epinal Operations - Claims team.

Warranty

Warranty is based on the general terms and conditions of the manufacturer. The warranty is void if the equipment is repaired or modified without the written approval of the manufacturer, if the operating limits are exceeded or if the control system or the electrical wiring is modified. Damage due to misuse, lack of maintenance or failure to comply with the manufacturer's instructions or recommendations is not covered by the warranty obligation. If the user does not conform to the rules of this manual, it may entail cancellation of warranty and liabilities by the manufacturer.

Refrigerant

The refrigerant provided by the manufacturer meets all the requirements of our units. When using recycled or reprocessed refrigerant, it is advisable to ensure its quality is equivalent to that of a new refrigerant. For this, it is necessary to have a precise analysis made by a specialized laboratory. If this condition is not respected, the manufacturer warranty could be cancelled.



General information

Maintenance contract

It is strongly recommended that you sign a maintenance contract with your local Service Agency. This contract provides regular maintenance of your installation by a specialist in our equipment. Regular maintenance ensures that any malfunction is detected and corrected in good time and minimizes the possibility that serious damage will occur. Finally, regular maintenance ensures the maximum operating life of your equipment. We would remind you that failure to respect these installation and maintenance instructions may result in immediate cancellation of the warranty.

Training

To assist you in obtaining the best use of it and maintaining it in perfect operating condition over a long period of time, the manufacturer has at your disposal a refrigeration and air conditioning service school. The principal aim of this is to give operators and technicians a better knowledge of the equipment they are using, or that is under their charge. Emphasis is particularly given to the importance of periodic checks on the unit operating parameters as well as on preventive maintenance, which reduces the cost of owning the unit by avoiding serious and costly breakdown.

Contents

General information	2
General unit characteristics	6
Installation	
Unit name plate	8
Installing the unit	8
Duct connections	9
Water to evaporator connection	11
Minimum water volume	11
Water treatment	12
Antifreeze protection	12
Electrical connections	13
General start-up	
Start-up preparation	14
Start-up	14
Operation	
Unit operation	16
Weekly start up and week-end shutdown	16
Seasonal start-up and shutdown	16
Maintenance	
Maintenance instructions	17
Installation checklist	18
Troubleshooting guide	19



General unit characteristics

Table 1 - CGCL general data

		CGCL 200 R407C	CGCL 250 R407C	CGCL 300 R407C	CGCL 350 R407C	CGCL 400 R407C	CGCL 450 R407C	CGCL 500 R407C	CGCL 600 R407C
Eurovent Performances (1)									
Net cooling capacity	(kW)	49.2	61.1	74.0	86.9	101.0	111.0	126.0	152.0
Total power input in cooling	(kW)	21.9	26.9	34.6	38.3	46.8	55.5	59.7	73.1
Evaporator water pressure drop	(kPa)	42	41	42	41	39	46	56	68
Main power supply		400/3/50							
Sound power level 300 Pa	(dB(A))	88	84	87	89	91	95	90	94
Sound power level 400 Pa	(dB(A))	90	86	89	90	93	96	92	95
Sound power level 500 Pa	(dB(A))	91	88	90	92	94	97	93	96
Units Amps									
Nominal (4)	(A)	48	61.4	76.7	86.1	102.3	117.7	120.8	151.3
Start-up amps	(A)	150	209	224	234	250	265	268	299
Recommended fuse size (Am)	(A)	Depends on installation							
Max supply cable size	(mm ²)	35	35	50	50	95	95	95	95
Max. wire length	(m)	Depends on installation							
Compressor									
Number (circ 1/ circ 2)		2	2	2	3	3	3	2/2	2/2
Type		Scroll							
Model		10T+10T	10T+15T	2x15T	2x10T+15T	10T+2x15T	3x15T	2x(10T+15T)	4x15T
Number of speeds		1	1	1	1	1	1	1	1
Number of motors		1	1	1	1	1	1	1	1
Rated amps (2)(4)	(A)	37	46	55	65	74	83	92	110
Locked rotor amps (2)	(A)	139	194	203	212	221	230	240	258
Motor RPM	(rpm)	2900	2900	2900	2900	2900	2900	2900	2900
Sump heater (2)	(W)	-	-	-	-	-	-	-	-
Evaporator									
Number		1							
Type		Brazed plate							
Water volume (total)	(l)	4.7	5.9	7.0	8.2	10.5	10.5	12.3	16.1
Antifreeze Heater	(W)	65	65	65	65	65	65	130	130
Water connection type		Male ISO R7							
Water connection diameter		1"1/2	1"1/2	1"1/2	2"	2"	2"	2"1/2	2"1/2
Coil									
Type		Plate Fin							
Tube size	(mm)	9.52							
Tube type		Smooth							
Height	(mm)	914	1219	1219	1219	1219	1219	1626	1626
Length	(mm)	1829	1829	1829	2743	2743	2743	2743	2743
Face Area	(m ²)	1.67	2.23	2.23	3.34	3.34	3.34	4.46	4.46
Number of rows		4							
Fins per inch (fpf)		180							
Fan									
Type		Centrifugal							
Number		1	2	2	2	2	2	3	3
Diameter		AT 18-18							
Drive type		Belt Drive							
Number of speeds		2							
Number of motors		1							
Dimensions									
Height	(mm)	1997	1997	1997	1997	1997	1997	1997	1997
Length	(mm)	2268	2268	2268	3230	3230	3230	3230	3230
Width	(mm)	866	866	866	866	866	866	1216	1216
Weight uncrated	(kg)	710	830	890	1080	1140	1200	1380	1500
Weight crated	(kg)	750	870	930	1130	1190	1250	1450	1570
Refrigerant circuit data									
Number of circuits		1	1	1	1	1	1	2	2
Refrigerant charge A/B	(kg)	12/-	15/-	15/-	24/-	24/-	24/-	15/15	15/15
Oil charge A/B	(l)	7.6/-	10/-	12.4/-	13.8/-	16.2/-	18.6/-	10/10	12.4/12.4

(1) at Eurovent Conditions at nominal airflow (Evap 12°C/7°C - Air. 35°C)
(2) per motor
(3) per circuit
(4) 5°C saturated suction temperature - 60°C saturated discharge temperature



General unit characteristics

Table 2 - CGCL Fan performance

Size	Airflow (m ³ /h)			Total Fan Static Pressure (Pa)		
				300	400	500
CGCL 200	15300	Fan Motor Nominal Power Low Speed*	(kW)	0.75	1.1	1.1
		Fan Motor Nominal Power High Speed	(kW)	4.0	5.5	5.5
		Nominal Amps Low speed *	(A)	3.2	3.7	3.7
		Nominal Amps High speed	(A)	8.9	11	11
		Starting Amps *	(A)	14	12	12
CGCL 250	17800	Fan Motor Nominal Power Low Speed*	(kW)	0.75	1.1	1.5
		Fan Motor Nominal Power High Speed	(kW)	4.0	5.5	7.5
		Nominal Amps Low speed *	(A)	3.2	3.7	5.0
		Nominal Amps High speed	(A)	8.9	11	15.3
		Starting Amps *	(A)	14	12	17
CGCL 300	23800	Fan Motor Nominal Power Low Speed*	(kW)	1.5	1.5	2.8
		Fan Motor Nominal Power High Speed	(kW)	7.5	7.5	11.0
		Nominal Amps Low speed *	(A)	5.0	5.0	7.7
		Nominal Amps High speed	(A)	15.3	15.3	21.5
		Starting Amps *	(A)	17	17	33
CGCL 350	26800	Fan Motor Nominal Power Low Speed*	(kW)	1.5	2.8	2.8
		Fan Motor Nominal Power High Speed	(kW)	7.5	11.0	11.0
		Nominal Amps Low speed *	(A)	5.0	7.7	7.7
		Nominal Amps High speed	(A)	15.3	21.5	21.5
		Starting Amps *	(A)	17	33	33
CGCL 400	30600	Fan Motor Nominal Power Low Speed*	(kW)	2.8	2.8	3.8
		Fan Motor Nominal Power High Speed	(kW)	11	11	15
		Nominal Amps Low speed *	(A)	7.7	7.7	10.1
		Nominal Amps High speed	(A)	21.5	21.5	28.6
		Starting Amps *	(A)	33	33	43
CGCL 450	34500	Fan Motor Nominal Power Low Speed*	(kW)	3.8	3.8	4.8
		Fan Motor Nominal Power High Speed	(kW)	15.0	15.0	18.5
		Nominal Amps Low speed *	(A)	10.1	10.1	12.1
		Nominal Amps High speed	(A)	28.6	28.6	34.6
		Starting Amps *	(A)	43	43	45
CGCL 500	39100	Fan Motor Nominal Power Low Speed*	(kW)	2.8	3.8	3.8
		Fan Motor Nominal Power High Speed	(kW)	11.0	15.0	15.0
		Nominal Amps Low speed *	(A)	7.7	10.1	10.1
		Nominal Amps High speed	(A)	21.5	28.6	28.6
		Starting Amps *	(A)	33	43	43
CGCL 600	47600	Fan Motor Nominal Power Low Speed*	(kW)	4.8	4.8	5.3
		Fan Motor Nominal Power High Speed	(kW)	18.5	18.5	22.0
		Nominal Amps Low speed *	(A)	12.1	12.1	13.2
		Nominal Amps High speed	(A)	34.9	34.9	40.9
		Starting Amps *	(A)	45	45	48

*: Fan motor always starts in Low speed

Unit nominal amps = nominal fan amps (according to static pressure) + compressor nominal amps

Unit starting amps = nominal fan amps (according to static pressure) + compressor starting amps

Table 3 - Pressure drop through condenser coil and air filter

Unit	Airflow m ³ /h	Chiller internal pressure drop (Pa)			
		Cds coil	AR300 filter	A150 Filter	M8 Filter
CGCL 200	15300	96	100	66	28
CGCL 250	17800	77	85	56	22
CGCL 300	23800	124	122	84	40
CGCL 350	26800	77	85	56	22
CGCL 400	30600	96	100	68	28
CGCL 450	34500	117	117	80	36
CGCL 500	39100	124	95	64	26
CGCL 600	47600	163	122	84	40

For minimum clearance, consult the certified submittals, which are available on request from your local Trane sales office.

Available static pressure = Total fan static pressure (from table 2) - Chiller internal pressure drop (from table 3)

IMPORTANT: The setting of the external static pressure supplied by the CGCL chiller must correspond to the actual ductwork (inlet and outlet) pressure drop +/- 50Pa. Failure to comply to this condition could lead to operational problems such as excessive sound levels, vibrations, or early wear of motor, fan or bearings. Adjustment of the airflow through the unit must be performed at chiller commissioning or warranty will not apply.

Installation

Selection of the Proper Available Static Pressure:

Static pressure indicated only takes into account the available pressure of the fan. It is necessary to subtract the pressure drop of the components from Table 3. Failure to do so will end up in increasing constraint on the bearings and on the motor which will result up in a drastic reduction of the lifespan of the fan.

For example:
CGCL 350

- with 400 Pa available static pressure fans
- with 77 Pa condenser coil
- with A150 Filter of 56 Pa

Available Static Pressure =
400 Pa - 77 Pa - 56 Pa = 267 Pa

The tolerance is +/- 50 Pa.

In this example the pressure drop of the ductwork will have to be between 217 Pa and 317 Pa.

Table 4 - Fan speed (rpm) : high speed (low speed)

Unit size	Available fan static pressure (Pa)		
	300	400	500
200	655 (328)	728 (364)	808 (404)
250	655 (328)	728 (364)	857 (429)
300	650 (325)	768 (384)	857 (429)
350	686 (343)	768 (384)	857 (429)
400	686 (343)	768 (384)	815 (408)
450	812 (406)	831 (416)	931 (466)
500	728 (364)	812 (406)	815 (408)
600	728 (364)	831 (416)	935 (468)

Unit nameplate

The unit nameplate gives the complete model reference numbers. The unit power rating is shown, and power supplies should not deviate by more than 5 % from the rated power.

Compressor motor amperage is shown in box I.MAX.
The customer's electrical installation must be able to withstand this current.

Installing the unit

Foundations

No special foundations are required, provided the supporting surface is flat and level, and can withstand the weight or the unit.

Isolation rubber pads

They are supplied as standard with the machine, and should be placed between the supporting floor and the unit to isolate the base from the ground.

- 4 pads for the sizes 200 to 300
- 6 pads for the sizes 350 to 600
- Trane does not allow to install spring isolators.

Water drain hole

Install a drain hole wide enough to drain away water from the unit in the event of shut-down or repair.

Clearance

Respect recommended clearance around the unit to allow maintenance operation to take place without obstruction and recommended clearance around condenser.

CAUTION! Unit operation is function of the air temperature. Any recycling of the air fed out by the fans will increase the air intake temperature over the condenser fins and can result in high pressure cut-out.

In this case the standard operating conditions are modified.

Operation of the unit may be affected by an increase in air temperature on the condenser. See submittals

Figure 1 - Handling

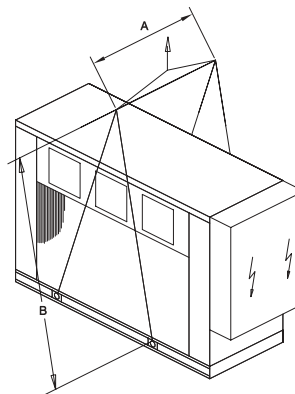

Note :

The plates welded at the end of the bases must not be used for handling.

Table 5 - Dimensions of recommended slings and swing-bar

CGCL	200	250	300	350	400	450	500	600
A (mm)	1150	1150	1150	1150	1150	1150	1500	1500
B (mm)	2550	2550	2550	2700	2700	2700	2700	2700
Weight (kg)	750	870	930	1130	1190	1250	1450	1570

Installation

Duct connections

Duct connections of suction and discharge of the unit and accessories must be made of flexible hose. The duct connection must be flexible enough to prevent transmitting vibrations to the tube network (see Figures 2, 3 and 4).

CAUTION!: When fixing the duct to the condenser inlet, make sure the fixing screws do not pierce the coil.

Figure 2

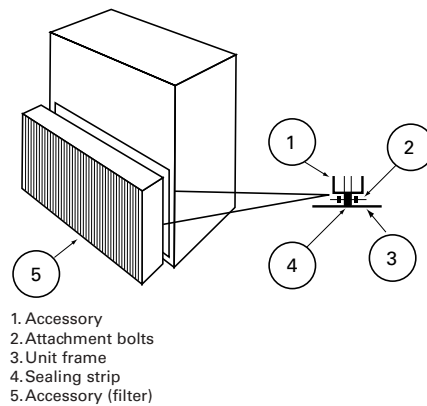

1. Accessory
2. Attachment bolts
3. Unit frame
4. Sealing strip
5. Accessory (filter)

Figure 3 - Inlet

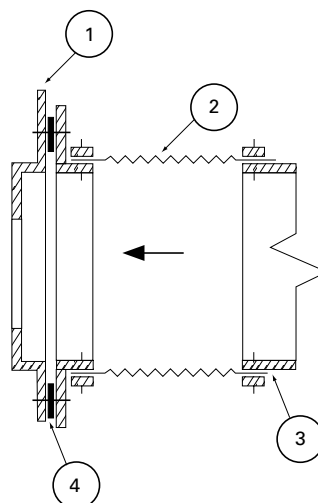

1. Unit body
2. Flexible coupling
3. Ductwork
4. Seal

Figure 4 - Outlet

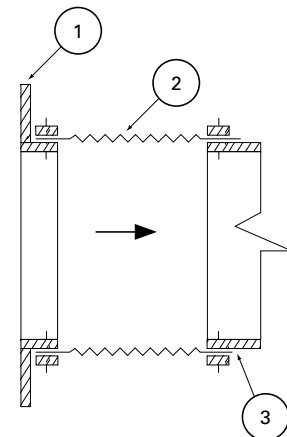

1. Unit body
2. Flexible coupling (field supply)
3. Ductwork

To prevent a reduction in fan efficiency, which would reduce the air flow and the unit's cooling capacity, the duct connections must be designed and connected according to normal trade practice.

Installation

CAUTION! If the duct network does not provide the external static pressure stipulated on selection, it will have repercussions on the air flow and therefore on the unit's performance.

Please refer to "Selection of the Proper Available Static Air Pressure".

This type of problem may if necessary be referred to the Trane service office, which may be able to advise you as to the necessary modifications, if any.

On all units, a straight duct section connected to a fan must have at least the same cross sectional area as the output panel orifice, and its minimum length must be one and a half times the fan diameter, before any bend or deviation.

There must be no tight bends, particularly at the fan output where the air velocity gradient is high. A large proportion of the air initially flows at the top of the duct. If a bend is close to the fan it must be installed so that its external curvature radius is in the trajectory of the air discharged by the high speed side of the fan (see figures 5 and 6).

Figure 5

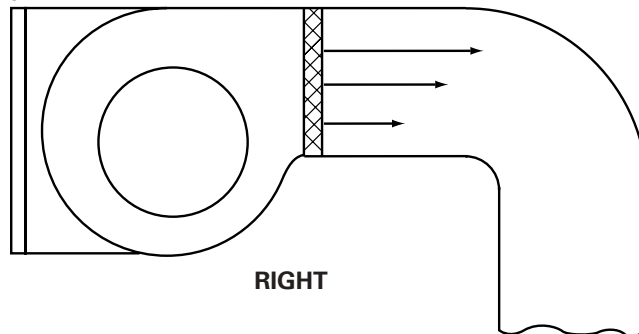
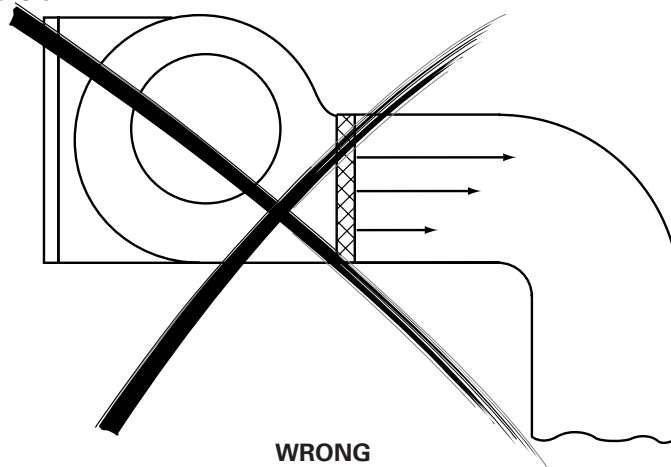

Figure 6



Installation

Water to evaporator connection

Before making any connections, make sure the labelling for entering and leaving water corresponds to the submittals.

Install water circulation pump upstream of the evaporator, insuring that the evaporator is under positive pressure.

Tables for water connections diameter are shown on the certified submittals.

These drawings are available on request from your Trane Sales Office.

Figure 7

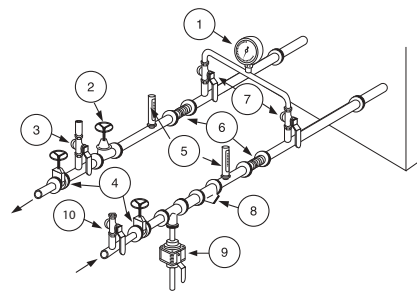

1. Pressure gauges: show entering and leaving water pressure (2 pressure ports are available inside of the unit - see item 1 in Figure 7)
2. Balancing valve: adjusts water flow.
3. Air purge allows to remove the air from the water circuit during fill up.
4. Stop valves: isolate chillers and water circulating pump during maintenance operations.
5. Thermometers: indicate chilled water entering and leaving temperatures (not mandatory).
6. Expansion compensators: avoid mechanical stress between chiller and piping installation.
7. Stop valve located on the outlet connection: used to measure the water pressure inlet or outlet of evaporator.
8. Strainer: avoid getting heat exchangers dirty. All installation must be equipped with efficient strainer in order that only clean water enters into exchanger. If there is no strainer, reserve will be formulated by the Trane technician at the start-up of the unit. The strainer used must be able to stop all particles with a diameter greater than 1.6 mm.
9. Draining and charging: used to drain and charge the plate heat exchanger.
10. Charging valve

Minimum water volume

Why the water volume is an important parameter?

The water volume is an important parameter because it allows a stable chilled water temperature and avoids short cycle operation of the compressors.

Parameters which influence the water temperature stability

- Water loop volume.
- Load fluctuation.
- Number of capacity steps.
- Compressors rotation.
- Dead band (adjusted by control CH530).
- Minimum time between 2 starts of a compressor.

Minimum water volume for a comfort application

For comfort application we can allow water temperature fluctuation at part load. The parameter to take into account is the minimum operating time of the compressor.

In order to avoid lubrication problem on a scroll compressor it must run at least 2 minutes (120 seconds) before it stops.

The minimum volume can be determined by using the following formula:

$$\text{Volume} = \text{Cooling capacity} \times \text{Time} \times \text{highest capacity step (\%)} / \text{Specific heat} / \text{Dead band}$$

Minimum operating time = 120 seconds

Specific heat = 4.18 kJ / kg

Average Dead band = 3°C (or 2°C)

Note: To estimate the biggest step, it is usually more reliable to make a selection at lower ambient temperature where efficiency is higher and compressors steps bigger. It is also essential to take into account the brine specific heat, in case of the use of glycol.

Table 6 - Recommended water loop volume at Eurovent conditions

	Unit size	200	250	300	350	400	450	500	600
Chiller data	Cooling Capacity full load (kW)	49.2	61.1	74.0	86.9	101.0	111.0	126.0	152.0
	Biggest step (%)	50	60	50	43	38	33	30	25
	Biggest step (kW)	24.6	36.7	37.0	37.2	37.9	36.6	37.8	38.0
Minimum water loop for comfort application (l)		235	351	354	356	363	350	362	364

This table is estimated with : 35°C ambient air temperature, 12/7°C water temperature, water (no glycol), deadband of 3°C.

Installation

Water treatment

Untreated or insufficiently treated water, if used in this unit, may cause scale, slime or algae to accumulate or cause erosion and corrosion. As Trane does not know the components used in the hydraulic network and the quality of the water used, we recommend the services of a qualified water treatment specialist. The following materials are used in Trane chillers heat exchangers :

- Stainless steel plates AISI 316, 1.4401 with copper brazing.
- Water piping: copper 99,9 %
- Water connections: brass

Trane will not accept any liability in regards of damage due to the use of untreated or improperly treated water or from the use of saline or brackish water. If required, contact your local Trane Sales Office.

Antifreeze protection

During negative ambient air temperature chilled water piping must be fully insulated. Insure that all safeties are taken to prevent frost damage during negative ambient air temperature. Following system can be used:

- Electrical heater mounted on all water piping exposed to negative temperatures.
- Start chilled water pump during negative ambient air temperature.
- Add ethylene glycol in the chilled water.

Figure 8 - Freezing point versus ethylene glycol percentage

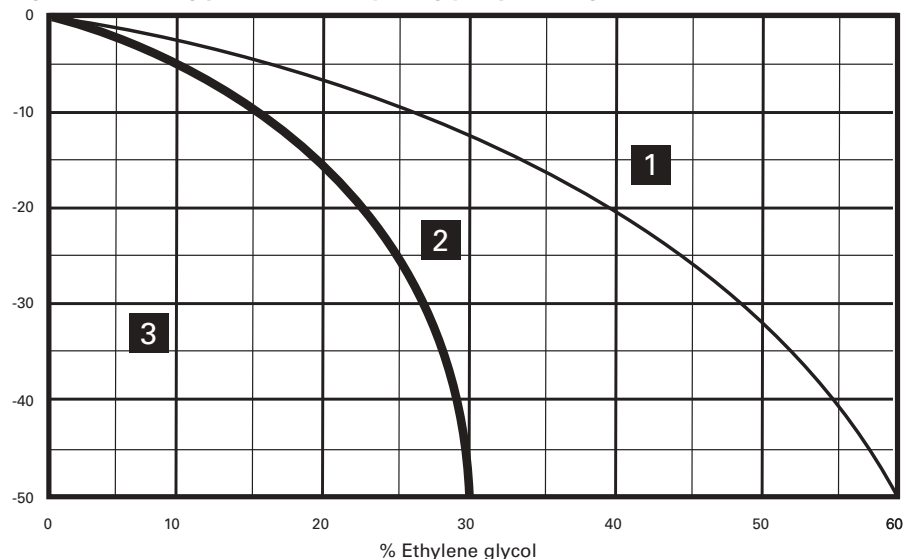

1. Liquid
2. Freezing without burst effect
3. Freezing with burst effect

Installation

Electrical connections

CAUTION!:

1. The greatest care should be taken when cutting through passages and installing electric wiring. Under no circumstances should chips of metal or cuttings of copper or isolating material fall into the starter panel or electric components. Relays, contactors, terminals and control wiring should be covered and protected before power supplies are connected.
2. Install power supply cabling as shown in wiring diagram.

Adequate cable gland should be chosen, ensuring no foreign bodies enter the electrical housing or components.

CAUTION!:

1. Cabling must comply with standards in force. The type and location of fuses must also comply with standards. As a safety measure, fuses should be visibly installed, close to the unit.
2. Only copper wiring should be used. Using aluminium wires can produce galvanic corrosion and possibly lead to superheat and failure of connection points.

Trane provides a single power supply which includes the transformer.

Warranty reserves will be formulated if a transformer, not supplied by Trane, is installed inside the electric panel.

CAUTION! Electrical connection to an IT Network is not recommended if the unit has been provided with a speed inverter such as the low ambient option (-18°C). Speed inverter generates earth current leakage that is not suitable for IT networks without special designed devices. For more information contact your local Trane Sales Office.

General start-up

Start-up preparation

Carry out all operations on check list and that the unit is correctly installed and ready to operate.

The installer must check all the following points before calling in the Trane Servicing Department to put the equipment into service:

- Check position of unit
- Check unit is level
- Check type and position of rubber pads
- Check clearance required for maintenance access (See submittals)
- Check clearance around condenser (See Submittals)
- Chilled water circuit ready to operate, filled with water, pressure test carried out and air purged.
- Chilled water circuit must be rinsed
- Check the presence of water strainer ahead of evaporator
- The strainers must be cleaned after 2 hours of pumps operation
- Check the thermometers and manometers position
- Check chilled water pumps interconnection to control panel
- Insure that the isolation resistance of all power supply terminals to ground complies with standards and regulations in force.
- Check that unit voltage and frequency supplied match rated input voltage and frequency
- Check that all electrical connections are clean and sound - Check that main power supply switch is sound.
- Check Ethylene glycol % in the chilled water circuit if Ethylene glycol presence is required.
- Check chilled water pressure drop through evaporator is in accordance with the Trane order write-up.
- On start-up of each motor in the system, check the direction of rotation and operation of all the components they drive
- Water flow control checking: decrease the water flow and check the electrical contact in the control panel.
- Check that there is sufficient demand for cooling on the day of start-up (around 50% of nominal load)

Start-up

Follow the instructions below to correctly start-up the unit.

Installation and chiller inspection:

- Ensure that all the operations above (start-up preparation), are followed.
- Follow the instruction stuck inside the electrical cabinet:
- Unscrew the screws securing the isolators located under the rails supporting the compressor.
- Put the plexiglass supplied by Trane in front of the power terminal.
- Insure all water and refrigerant valves are in service positions,
- Insure that the unit is not damaged,
- Insure that sensors are properly installed in their bulb-wells and submerged in heat conducting product,
- Check fixing of capillary tubes (protection from vibration and from wear) and insure that they are not damaged,
- Reset all manually set control devices,
- Check refrigerating circuits tightness

Checking and setting:

Compressors:

- Check oil level at rest. The level should reach at least halfway up indicator located on housing. See fig. 9 for correct level.

Figure 9 - Compressor oil level

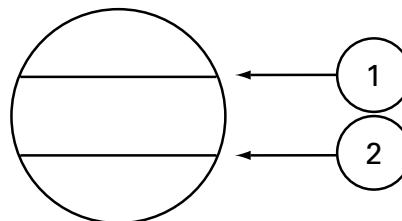

1. Max. oil level
2. Min. oil level

- Check fixing of capillary tubes (protection from vibration and from wear) and insure that they are not damaged,
- Reset all manually set control devices,
- Check refrigerating circuits tightness

- Check oil acidity,
- Check electrical terminals tightening of the motors and in the control panel,
- Check the isolation of the motors using a 500V DC megohmmeter which meets manufacturer's specifications (minimum value 2 megohms)
- Check the direction of the rotation using phasemeter.

Electrical power wiring:

- Check all the electrical terminals tightening,
- Set-up compressors overload relays,
- Set-up fan-motors overload relays,

Electrical control wiring:

- Check all the electrical terminals tightening,
- Check all the pressostats,
- Check and set-up the CH530 control
- Test and start-up without the electrical power.

Condenser:

- Check setting of the safety pressure valve,
- Check direction of the rotation of fans,
- Check the isolation of the motors using a 500V DC megohmmeter which meets manufacturer's specifications (minimum value 2 megohms)

Operating parameters statement:

- Switch on main power supply switch,
- Start the water pump(s),
- Start up the unit with CH530 by pushing "Auto".

The unit and the chilled water pumps contactor must be connected together,

- After unit start up, leave in operation for at least 15 minutes, to insure pressures are stabilized.

Then check:

- voltage,
- compressors and fan-motors currents,
- leaving and return chilled water temperature,
- suction temperature and pressure,
- ambient air temperature,
- blowing air temperature,
- discharge pressure and temperature.

General start-up

Check that the pressure drop on the condenser is in the tolerance of the fan

- Consult "Selection of the proper available static pressure"
- If the pressure does not comply then correction must be done either by changing pressure drop on the duct or by modifying the pulley or the motor.
- liquid refrigerant temperature and pressure,
- operating parameters:
- chilled water pressure drops through evaporator. It must be in accordance with Trane order write-up,
- superheat: difference between suction temperature and dew point temperature. Normal superheat must be within 5°C and 10°C,
- sub-cooling: difference between liquid temperature and bubble point temperature. Normal sub-cooling should be 2 to 5°C with R407C,
- difference between dew point temperature in high pressure and condenser air inlet temperature. Normal value on standard unit with R407C, should be 20 to 23°C.
- difference between outlet water temperature and dew point temperature in low pressure. Normal value on standard unit, without Ethylene glycol in chilled water, should be about 3°C with R407C.

Final check:

When the unit is operating correctly:

- Check that the unit is clean and clear of any debris, tools, etc...
- All valves are in operating position,
- Close control and starter panel doors and check panels fixation.

CAUTION!:

- For the warranty to apply, any start-up carried out directly by the customer must be recorded in a detailed report, which must be sent as soon as possible to the nearest Trane office.
- Do not start-up a motor whose insulation resistance is less than 2 megohms
- Phase imbalance should not be greater than 2%.
- The voltage supplied to motors should be within 5% of the rated voltage on the compressor nameplate.
- Excessive emulsion of the oil in the compressor shows that refrigerant is present in the oil and the result will be that compressor is not lubricated enough. Shut down compressor and consult Trane technician.
- Excess oil in compressor can damage the compressor. Before adding oil, consult Trane technician. Use only Trane products recommended.
- The compressors must operate in a single direction of rotation. If refrigerant high pressure remains stable in the 30 seconds after compressor start-up, immediately shut down unit and check the direction of rotation using phasemeter.

WARNING!

- The chilled water circuit may be under pressure. Bring down this pressure before opening up the system to rise out or fill up the water circuit. Failure to comply with this instruction may cause accidental injury to maintenance personnel.
- If a cleaning solution is used in the chilled water circuit, the chiller must be isolated from the water circuit to avoid all the damage risks of the chiller and evaporator water pipes.

Table 7 - Evaporator pressure drop

PD. (kPa)	Water flow (l/s)							
	CGCL 200	CGCL 250	CGCL 300	CGCL 350	CGCL 400	CGCL 450	CGCL 500	CGCL 600
10	1.155	1.449	1.736	1.912	2.282	2.282	2.500	2.700
20	1.631	2.045	2.447	2.809	3.343	3.343	3.561	3.853
40	2.301	2.886	3.448	4.129	4.898	4.898	5.074	5.499
60	2.815	3.530	4.215	5.172	6.125	6.125	6.241	6.771
80	3.248	4.072	4.860	6.068	7.177	7.177	7.228	7.848
100	3.629	4.550	5.427	6.868	8.116	8.116	8.100	8.800

When ethylene glycol is added in the chilled water circuit the following adjustment factors have to be taken in account.

Table 8 - Ethylene glycol adjustment factors

LWTE (%)	PCT EG		Adjustment factors		
	Flow rate	Pressure drop	Power Input	Cooling Cap.	
12	30	1.11	1.20	1.005	0.98
5	30	1.11	1.24	1.005	0.98
4	10	1.02	1.08	-	-
0	20	1.05	1.19	-	-
-4	27	1.08	1.29	-	-
-8	33	1.10	1.46	-	-
-12	37	1.12	1.62	-	-

Operation

Control System

The control is through the CH530 control module.

Unit operation

- Check the chilled water pump(s) operates
- Start up unit using CH530. The unit will operate correctly when there is sufficient water flow. The compressors will start up if the evaporator water leaving temperature is above the CH530 control module setpoint.

Weekly start up

- Check the chilled water pump(s) operates
- Start the unit through the control module.

Week end shutdown

- If the unit needs to be shut down for a short period of time, stop the unit through the control module.
- If the unit is shut down for a longer period, see under "Seasonal shutdown", below.
- Insure that all safeties are taken to prevent frost damages during negative ambient temperature. (see page 5)
- Do not put the general and control disconnect switches to off.

Seasonal shutdown

- Check water flows and interlocks.
- Check Ethylene glycol % in the chilled water circuit if glycol presence is required
- Carry out leak test.
- Carry out oil analysis
- Record operating pressures, temperatures, amperages and voltage.
- Check operation of machines/compare conditions of operation against original commissioning data.
- Stop the unit through the control module.
- Insure that all safeties are taken to prevent frost damages during negative ambient temperature. (see page 5)

- Fill out the visit log sheet and review with the operator - Do not put the general and control disconnect switches to off.

Seasonal start-up

- Check water flows and interlocks.
- Check Ethylene glycol % in the chilled water circuit if glycol presence is required
- Check operational set points and performance.
- Calibrate controls.
- Check operation of all safety devices.
- Inspect contacts and tighten terminals.
- Megger the motor compressor windings.
- Record operating pressures, temperatures, amperages and voltage.
- Carry out leak test.
- Check configuration of unit control module.
- Change the oil as required based upon results of the oil analysis made during seasonal shutdown
- Check operation of machines/compare conditions of operation against original commissioning data.
- Fill out the visit log sheet and review with the operator

Maintenance

Maintenance Instructions

The following maintenance instructions are part of maintenance operations required for this equipment. A qualified technician is needed for regular maintenance as part of a regular maintenance contract.

Carry out all operations as required by schedule. This will insure long unit service life and reduce the possibility of serious and costly breakdown.

Keep service records up to date, showing monthly information on unit operations. These records can be of great help to maintenance personnel diagnostics.

Similarly, if machine operator keeps a log of changes in unit operating conditions, problems can be identified and solutions found before more serious problems arise.

Inspection visit after the first 500 hours of operation from unit start up

- Carry out oil analysis
- Carry out leak test.
- Inspect contacts and tighten terminals.
- Record operating pressures, temperatures, amperages and voltage.
- Check operation of machines/compare conditions of operation against original commissioning data.
- Fill out inspection visit log sheet and review with the operator
- Check that the condenser pressure drop and air flow conforms to start-up measurements.

Monthly preventive visit

- Carry out leak test.
- Oil test of acidity
- Check Ethylene glycol % in the chilled water circuit if glycol presence is required
- Inspect contacts and tighten terminals.
- Record operating pressures, temperatures, amperages and voltage.
- Check operation of machines/compare conditions of operation against original commissioning data.
- Fill out visit log sheet and review with the operator.

Annual preventive visit

- Check water flows and interlocks.
- Check Ethylene glycol % in the chilled water circuit if glycol presence is required
- Check operational set points and performance.
- Calibrate controls.
- Check operation of all safety devices.
- Inspect contacts and tighten terminals.
- Megger the motor compressor windings.
- Record operating pressures, temperatures, amperages and voltage.
- Carry out leak test.
- Check configuration of unit control module.
- Carry out oil analysis
- Change the oil as required based upon results of the oil analysis
- Check operation of machines/compare conditions of operation against original commissioning data.
- Fill out the annual start up visit log sheet and review with the operator.
- Check that the condenser pressure drop and air flow conforms to start-up measurements.

CAUTION!:

- Please refer to specific Trane documentation on oil, available from your nearest Trane office. Oils recommended by Trane have been exhaustively tested in Trane laboratories to the specific requirement of Trane chiller and hence the user's requirements. Any use of oils not meeting specifications recommended by Trane is the responsibility of the user only, who thereby is liable to warranty loss.
- Oil analysis and oil test acidity must be carried out by a qualified technician. Poor interpretation of results may cause unit operating problems. Also, oil analysis must follow the correct procedures, to avoid accidental injury to maintenance personnel.
- If the condensers are dirty, clean them with brush. If the coils are too dirty, consult a cleaning professional. Never use water to clean condenser coils.
- Contact Trane for information on maintenance contracts.

WARNING!

- Switch off unit main power supply before to any intervention. Failure to follow this safety instruction can lead to accident death of the maintenance personnel and may also destroy equipment.
- Never use steam or hot water above 55°C to clean condenser coils. The resulting increasing pressure could cause refrigerant lost through the safety valve.



Maintenance

Installation checklist

This list must be checked off by the installer to ensure correct installation before the unit start up.

UNIT POSITION

- Check clearance around condenser
- Check clearance required for maintenance access
- Check type and position of rubbers pads

CHILLED WATER CIRCUIT

- Check thermometers and manometers presence and position
- Check water flow rate balancing valve presence and position
- Check presence of strainer ahead of evaporator
- Check presence of air-purge valve
- Check rinsing and filling of chilled water pipes
- Check water pump(s) contactor interconnected to control panel
- Check water flow
- Check chilled water pressure drop through the evaporator

ELECTRICAL EQUIPMENT

- Check installation and rating of mains power switch/fuses
- Check electrical connections complied with specification
- Check that electrical connections are in accordance with information on manufacturer's identification plate
- Check direction of rotation using phasemeter

Comments

.....

Signature:.....Name:.....

Order N°:

Work site:

Please return to your local Trane Service Office

Maintenance

Troubleshooting guide

These are simple diagnostic hints. If there is a breakdown, the Trane Service office should be contacted for confirmation and assistance.

Symptom	Problem cause	Recommended action
A) The compressor does not start up		
Compressor terminals are live but motor does not start	Motor burned out.	Replace compressor
Contact motor not operational.	Coil burned out or broken contacts.	Repair or replace.
No current ahead of motor contactor.	a) Power cut. b) Main power supply switched off.	Check fuses and connection. See why system tripped. If system is operational, switch on main power supply.
Current ahead of fuse, but not on contactor side.	Fuse blown.	Check motor insulation. Replace fuse.
Low voltage reading on voltmeter.	Voltage too low.	Contact power Supply Utility.
Starter coil not excited.	Control circuit open.	Locate regulation device which has tripped out and see why. See instructions concerning this device. Replace compressor.
Compressor does not run. Compressor motor" groans".	Compressor sticking (damaged or sticking components).	See instructions for "discharge pressure high".
High pressure switch tripped to contacts open on high pressure.	Discharge pressure too high	Clean coil
Discharge pressure too high.	Dirty coil Not enough airflow	Increase fan speed Change or adjust drive
B) Compressor stops		
Over current thermal relay tripped.	Discharge pressure too high. a) Voltage too low. b) Cooling demand too high, or condensing temperature too high.	See instructions for "discharge pressure high". a) Contact Power Supply Utility. b) See instruction "discharge pressure too high".
Motor temperature thermostat tripped.		Repair leak. Add refrigerant.
Anti-freeze security tripped.	Not enough refrigerant.. Water flow to evaporator too low. Air filters dirty	Check water flow rate, and pressure switch contact in water. Clean or replace air filters
C) Compressor stops just after its start		
Suction pressure too low. Filter drier iced up.	Filter drier clogged.	Replace filter drier.

Maintenance

Symptom	Problem cause	Recommended action
D) The compressor keeps running without stopping		
Temperature too high in areas requiring air-conditioning.	Excess load on cooling system.	Check thermal insulation and air-tightness of areas requiring air-conditioning.
Chilled water temperature output too high.	Excess cooling demand on system.	Check thermal insulation and air-tightness of areas requiring air-conditioning.
E) Loss of oil in compressor		
Oil level too low in indicator.	Not enough oil.	Contact Trane office before to order oil
Gradual fall in oil level.	Filter drier clogged.	Replace filter drier.
Suction line too cold.	Liquid flows back to compressor.	Adjust superheat and check bulb fixing of the expansion valve.
F) Compressor noisy		
Compressor knocks.	Components broken in compressor.	Change compressor.
Suction duct abnormally cold.	a) Uneven liquid flow. b) Expansion valve locked in open position.	a) Check superheat setting and fixing of expansion valve bulb. b) Repair or replace.
G) Insufficient cooling capacity		
Thermostatic expansion valve "whistles".	Not enough refrigerant.	Check refrigerant circuit tightness and add refrigerant.
Excess pressure drops through filter drier	Drier filter clogged.	Replace.
Excessive superheat.	Superheat not properly adjusted.	Check adjustment of superheat and adjust thermostatic expansion valve.
Insufficient water flow.	Chilled water pipes obstructed.	Clean pipes and strainer.
H) Discharge pressure too high		
Condenser abnormally hot.	Presence of uncondensable liquids in system, or excess refrigerant.	Purge uncondensable fluids and drain off excess refrigerant.
Chilled water leaving temperature too high.	Overload on cooling system.	Reduce load on system. Reduce water flow if necessary.
Condenser air output too hot.	Reduced air flow. Air intake temperature higher than specified for unit	Clean or replace air filters. Clean coil. Check operation of motor fans. See "Condenser fan"

Maintenance

Symptom	Problem cause	Recommended action
I) Suction pressure too high		
Compressor operates continuously. Suction duct abnormally cold.	Excess cooling demand on evaporator a) Expansion valve too far open. b) Expansion valve locked in open position.	Check system. a) Check for superheat and check that expansion valve bulb is secure. b) Replace.
Refrigerant flows back to compressor.		
J) Suction pressure too low		
Excessive pressure drop through filter drier. Refrigerant does not flow through thermostatic expansion valve.	Drier filter clogged. Expansion valve bulb has lost its refrigerant.	Replace the filter drier. Replace the bulb.
Loss of power.	Expansion valve obstructed.	Replace.
Superheat too low.	Excessive pressure drops through evaporator.	Check adjustment of superheat and adjust thermostatic expansion valve.
K) Insufficient cooling capacity		
Low pressure drops through evaporator	Low water flow rate.	Check water flow rate. Check state of strainer, check for obstruction in chilled water pipes. Check pressure switch contact in water.
L) Condenser fan		
Pulsing noise on fan outlet and duct work Fan Motor Amps too high	Too much airflow. Fan Available Static Pressure not according duct friction losses	Reduce RPM. Change drive.
Hissing noise at start	Belt tension too loose	Adjust belt tension.
Vibrations-Noise	Fan wheel out of balance Pulleys/ belt loosened Shaft bent Worn bearings	Correct balancing Tighten the drive Change shaft Change bearings

Note:

The above is not a comprehensive analysis of the Scroll compressor refrigeration system. The aim is to give operators simple instructions on basic unit processes so that they have the technical knowledge to identify and bring defective operations to the notice of qualified technicians.



Notes

Notes



Literature Order Number	CGCL-SVX01B-E4
Date	0406
Supersedes	CGCL-SVX01A-E4_0701
Stocking Location	Europe

Trane has a policy of continuous product and product data improvement and reserves the right to change design and specifications without notice. Only qualified technicians should perform the installation and servicing of equipment referred to in this publication.

www.trane.com

For more information, contact your local sales office or e-mail us at comfort@trane.com

American Standard Europe BVBA
Registered Office: 1789 Chaussée de Wavre, 1160 Brussels - Belgium